

# AudioCodes Enabling Technology Products

## AC494 Voice over Packet SoC Family



- Best suited for IP Phones and CPE VoIP Gateways
- Linux and VxWorks Board Support Packages
- Development Platform for Quick Time-to-market
- Lead-free available

AudioCodes' **AC494/5/6/7** family of System on Chip (SoC) provides IP phone and Customer Premises Equipment (CPE) manufacturers with cutting-edge VoIP processing system capabilities. The AC494 family combines MIPS™ Controller, AC49x DSP Core and a rich set of peripherals such as Codecs, Ethernet MACs and Phys, integrated 3 Port Switch and more. Several silicon derivatives of this family allow cost optimization per application.

### REDUCED COST AND RISK

The AC494 is based on VoIPerfect™ architecture, AudioCodes' underlying, best-of-breed, core media gateway technology for all of its products. Utilizing its highly integrated structure, requiring only minimal number of peripheral devices, time-to-market is fast and risk is minimal. The AC494 SoC combines 1 to 6 channels of toll quality low bit rate voice compression, G.168-2002 compliant echo canceller, T.38 Fax Relay, Caller ID, Adaptive Jitter Buffer and more. The VxWorks and Linux Board Support Package, together with H.323/SIP/MGCP software stacks, provides the customer with a fully-equipped VoIP vehicle ready to go.

### AC494 Functional Block Diagram

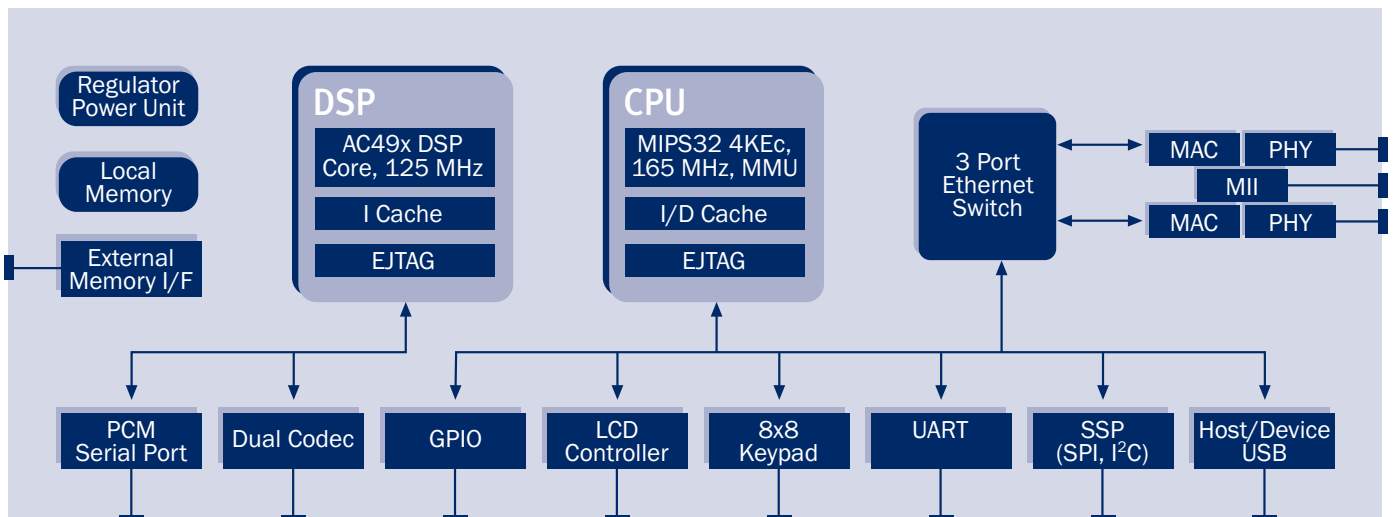

# AudioCodes Enabling Technology Products

## AC494

### SoC SPECIFICATIONS

CPU	MIPS32™ 4KEc™ 32-bit RISC Processor with MMU 165 MHz, providing up to 223 Dhrystone MIPS Enhanced JTAG IEEE 1149.1 for single-stepping of the processor
DSP	AC49x Core, 125 MHz
External Memory I/F	Two SDRAM banks, up to 128 MB, Flash up to 32 MB
Telephony Interface	Integrated dual channel 16 bit CODEC, sampling rate 8/16 KHz Five inputs to ADC, Four output from DAC
PCM Interface	2.048 MHz A/μ-Law serial port
Ethernet Subsystem	2 integrated 10/100 Base-T MAC/PHY ports Integrated 3-port wire speed Layer-2 Ethernet Switch
Keypad Interface	8x8 matrix , H/W debounce
LCD Interface	Alphanumeric; Micro interface graphic displays; Rasterized graphic display up to 1024x1024 pixels
USB Interface	USB 1.1 device/host controller and PHY
Power Supply	+3.3V (+1.5V core via integrated voltage regulator)
Power Consumption	1.88 W (max)
Operational Case Temperature Range	0°C - 70°C (commercial)
Package	324 pin BGA, 23x23 mm, 1.00 mm ball spacing

### SOFTWARE SPECIFICATIONS

DSP	
Channel Density	Up to 6 channels
Voice Coders	G.711, G.723, G.729, G.722.2, iLBC, G.722*
Echo Canceller	G.168-2002 compliant; Full duplex acoustic EC
3/4 Way Conferencing	Conferencing of 3/4 participants from PSTN or IP
Quality Enhancement	Voice Activity Detection (VAD), Comfort Noise Generation (CNG), Packet Loss Concealment (PLC), Adaptive Jitter Buffer (up to 300 msec)
Voice/Fax/Data discrimination	Automatic detection and switching
Fax Support	T.38 compliant G3 Fax Relay
Signaling	DTMF TIA 464B, User Defined tones
Caller ID	Telcordia (Bellcore), ETSI, NTT On Hook and Off Hook Service (Type 1&2)
RTP/RTCP	Per RFC 3350, 3351, 2198
SRTP Encryption	Per RFC 3711, 128 bit AES, Authentication: HMAC SHA1
DTMF Relay	Per RFC 2833
Embedded Software	
Board Support Package	For Linux and VxWorks
Demo Application	For IP Phone and CPE applications
Call Control Protocols	H.323/SIP/MGCP

Device	CPU Clock	Eth. Ports	USB	Voice CODEC
AC494	165 MHz	2	✓	✓
AC496	165 MHz	2	–	–
AC495	125 MHz	2	–	✓
AC497	125 MHz	1	–	✓

### APPLICATIONS

- Terminal Adapters, IADs
- Analog Media Gateways
- IP Phones

### ABOUT AUDIOCODES

AudioCodes Ltd. (NASDAQ: AUDC) enables the new voice infrastructure by providing innovative, reliable and cost-effective Voice over Packet technology and Voice Network products to OEMs, network equipment providers and system integrators. AudioCodes provides its customers and partners with a diverse range of flexible, comprehensive media gateway and media processing technologies, based on VoIPerfect™ – AudioCodes' underlying, best-of-breed, core media gateway architecture. The company is a market leader in voice compression technology and is a key originator of the ITU G.723.1 standard for the emerging Voice over IP market. AudioCodes voice network products feature media gateway and media server platforms for packet-based applications in the converged, wireline, wireless, broadband access, and enhanced voice services markets. AudioCodes enabling technology products include VoIP and CTI communication boards, VoIP media gateway processors and modules, and CPE devices. AudioCodes' headquarters and R&D facilities are located in Israel with an R&D extension in the U.S. Other AudioCodes' offices are located in Europe, the Far East, and Latin America.

#### International Headquarters

1 Hayarden Street, Airport City  
Lod, Israel 70151  
Tel: +972-3-976-4000  
Fax: +972-3-976-4040

#### US Headquarters

2099 Gateway Place, Suite 500  
San Jose, CA 95110  
Tel: +1-408-441-1175  
Fax: +1-408-451-9520

info@audiocodes.com  
www.audiocodes.com

© 2005 AudioCodes Ltd. All rights reserved. AC, Ardito, AudioCodes, AudioCodes logo, AudioCoded, IPmedia, Mediant, MediaPack, MP-MLQ, NetCoder, Stretto, TrunkPack, VoicePacketizer and VoIPerfect are trademarks or registered trademarks of AudioCodes Ltd. All other marks are the property of their respective owners. The information and specifications in this document and the product(s) are subject to change without notice.

Ref. # LTRT-00293 08/05 V.3



\* Please contact AudioCodes representative for specific software availability